



ASP
Filtration Group®

Zero Loss Demand Drain

Electric Operated Condensate Drain System

Exactronic Drain System



Combines the best of float type drains and timer operated ball valve drains.

Translucent reservoir for visual assurance of operation.

Features

Large 50 oz. capacity

No wasted air

Non clogging

Translucent reservoir

Isolated trigger mechanism

Full port ball valve

Benefits

Ideal for most compressor applications

Saves energy

No strainers to clean

Easy-to-see condensate level
"Quick check"

Ensures both a positive opening and closing to prevent air loss

Handles scale and rust without clogging

Model No. EDS-2BV

Specifications

Inlets: 1/2" NPT

Outlet: 1/4" NPT

Pressure: 0 to 200 PSI

Operating Temperature: 35° to 1400° F.

Weight: 20 lbs.

Discharge: 0.4 Gal. per cycle, 100 PSI

Voltage: 120V, 60 Hz., 1 Ph.

Electrical Rating: Nema 4X

Materials

Reservoir: Aluminum and Composite

Valve: Bronze w/S.S. Ball and Stem

Float: Stainless Steel

Seat: Stainless Steel

Seal: Viton®*

Consult factory for Optional Remote Alarm Contacts and other options

Dimensions

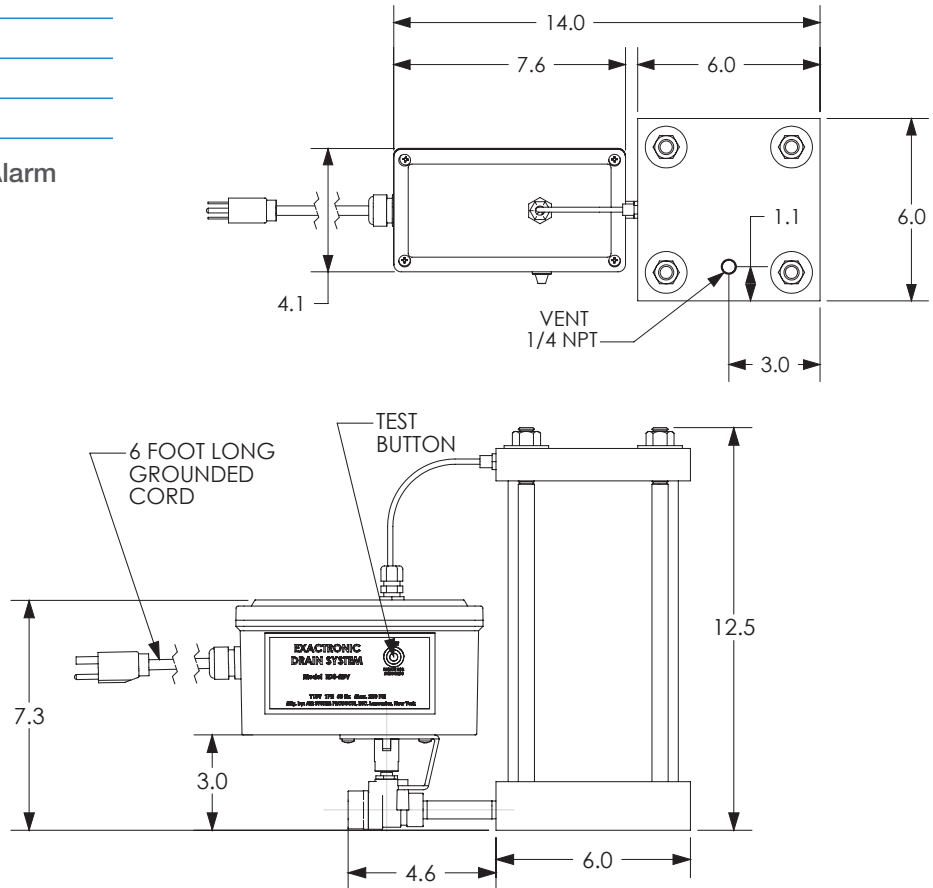
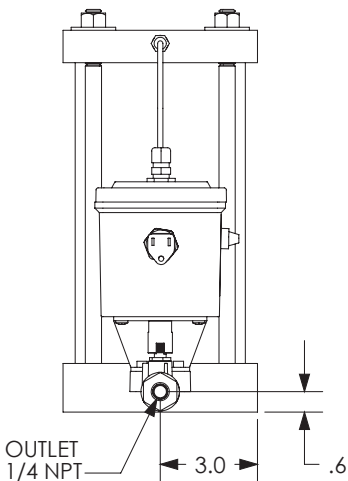

How It Works

Condensate enters the drain through one of two inlet connections. As condensate is collected and the translucent reservoir fills, a stainless steel level switch rises. When the condensate reaches a design level, the level switch sends a signal to the electric valve actuator which in turn opens a full-port drain.

Condensate will then exit the unit. As the level switch drops, a signal is sent to the valve actuator to close the ball valve. The drain is then returned to the collection mode.



AIR SYSTEM PRODUCTS

51 Beach Ave.
Lancaster, NY 14086
Phone: 716.683.0435
Fax: 716.683.7128
Email: info@airsyspro.com
www.filtrationgroup.com

All design specifications are subject to change without notice.

* Viton is a registered trademark of E. I. DU PONT DE NEMOURS & COMPANY CORPORATION.

© 2017 FGA-022-072817-02